

De Projectinrichter

REPUBLIC OF **Fritz Hansen**<sup>®</sup>

[www.deprojectinrichter.com](http://www.deprojectinrichter.com)  
088 - 650 12 34

NAP™



The Danish designer Kasper Salto has designed the NAP™ chair for Fritz Hansen. NAP is a series of light stacking chairs designed for optimum sitting comfort regardless of the sitting position. NAP is an abbreviation of Normal, Active and Passive – because sitting is in actual fact constant movement.



## KASPER SALTO 1967-

Kasper Salto was originally trained as a cabinet maker and later graduated in 1994 from the Danish Design School. In Kasper Salto's work the Danish tradition of furniture design is continued in a well-balanced combination with international industrial design and its new trends. Salto's main source of inspiration is nature and its way of colouring. Kasper Salto has already received several design awards for his work. Salto has also designed the Ice™ series and Little Friend™.



## DESIGN

Kasper Salto, 2010

## DESCRIPTION

Chairs designed by Kasper Salto, manufactured by Fritz Hansen.

NAP is available in six varieties, with and without armrests. The back of the shell has a high-gloss surface, and the front is matt and ribbed to emphasise the geometry of the chair. To minimise undesired noise and the risk of floor marks, the front and back leg ferrules have different sizes. All varieties come in four different colours: Milk White, Butter Yellow, Pepper Grey, Coffee Brown. The shell is moulded and dyed through in nylon (Polyamide – PA6), which allows the material to be recycled. The underside cover and the spacing blocks are made of nylon and TPE (Thermo Plastic Elastomer), respectively. Both are dyed through in the colour of the shell. The frame is made of 14 mm steel and powder coated in colours corresponding to the shell, or in chromed steel. The leg ferrules are made of black TPE. The chair stacks 8-10 units at a time with and without arm rests.

## UPHOLSTERY

NAP is also available with seat upholstery – the upholstery may also be purchased separately and mounted later or be replaced. The seat cushion is made of PE foam with velour hooks on the reverse side and fabric on top, thickness 5 mm. The cushion is available in Divina fabric from Kvadrat in a selection of ten predefined colours.

## ENVIRONMENT & TESTS

For environmental reasons the chair can easily be dismantled and recycled. The main chair component – nylon, is a plastics material used in our everyday lives, and the chair is therefore suitable for recycling. The plastic can be granulated, and steel parts can be recycled. The chair has been tested and approved according to EN 15373 for Strength, Durability and Stability - test level 2 general contract use, EN 1728 Strength and Durability and EN 1022 Stability.

## VARIATIONS & DIMENSIONS

### MODEL KS50

Seat height: 45, 47.5 cm

Height: 77 cm

Width: 54 cm

Depth: 51 cm

### MODEL KS60

Seat height: 45, 47.5 cm

Height: 77 cm

Width: 62 cm

Depth: 51 cm

### Model KS58

Seat height: 64 cm

Height: 97 cm

Width: 56 cm

Depth: 52 cm

### MODEL KS68

Seat height: 64 cm

Height: 97 cm

Width: 62 cm

Depth: 52 cm

### Model KS59

Seat height: 76 cm

Height: 109 cm

Width: 56 cm

Depth: 54 cm

### MODEL KS69

Seat height: 76 cm

Height: 109 cm

Width: 62 cm

Depth: 54 cm

## WARRANTY

Standard goods have warranty for five years against manufacturing defects (i.e. materials and design). The warranty does not cover leather and other fabrics ordered as customers own or special material. Normal wear and tear and damage of covers are not covered by the warranty. Fritz Hansen offer up to 20 years limited warranty if the products are registered online at [fritzhenzen.com/my-republic](http://fritzhenzen.com/my-republic). The warranty for wicker, rugs and lamps is 2 years.

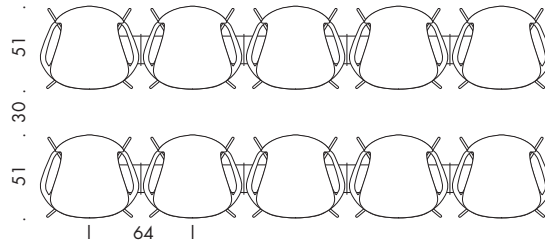
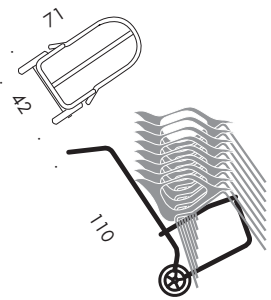
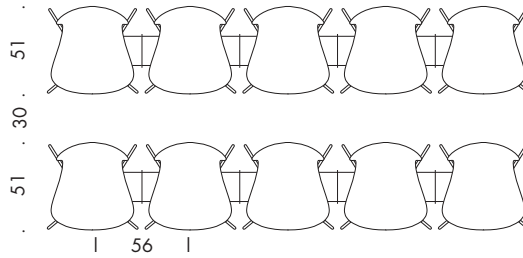
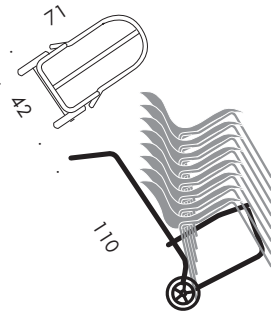
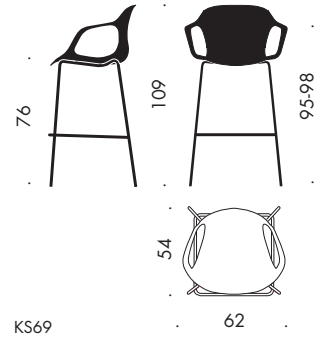
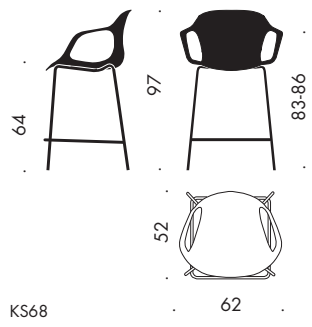
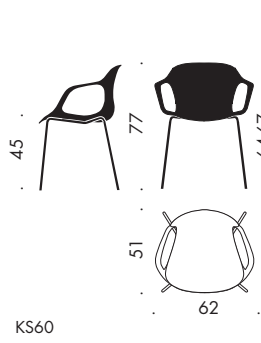
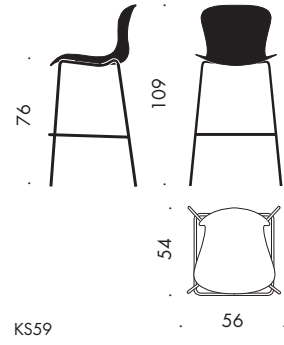
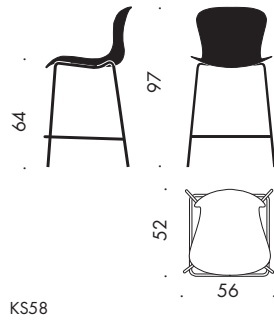
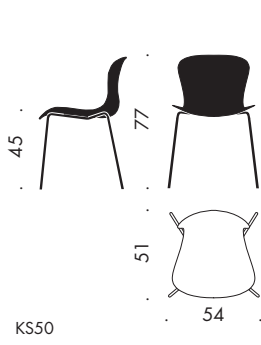

De Projectinrichter

[www.deprojectinrichter.com](http://www.deprojectinrichter.com)  
088 - 650 12 34



FRITZHANSEN.COM